



**MANUAL – INSTALLATION**

---

# **| Fan Column**

**v200 – Issue Date: 10/01/21**

© 2021 Price Industries Inc. All rights reserved

**PRICE®**

# FAN COLUMN

## TABLE OF CONTENTS

### Product Overview

General Safety Information .....	1
Safety Notices.....	1
Unit Description.....	2
Unit Inspection .....	2

### Installation & Start-up Instructions

Mechanical Installation .....	3
Electrical Installation .....	6
Hot Water and Chilled Water Coil Connections.....	7
Installation Checklist.....	8
Typical Sequence of Operation .....	11

### Maintenance

Maintenance .....	11
Price PFC Start-up Report .....	12
Price PFC Quality Assurance Report .....	14
Service and Warranty Procedure .....	15



### **FIRE OR EXPLOSION HAZARD**

Failure to follow safety warning exactly could result in serious injury, death or property damage.

Be sure to read and understand the installation, operation and service instructions in this manual.

Improper installation, adjustment alteration, service or maintenance can cause serious injury, death or property damage.

- Do not store or use gasoline or other flammable vapors and liquids in the vicinity of this or any other appliance.

### **MANUFACTURED BY** ▼

Price Industries Inc.  
20 Crestridge Drive  
Suwanee, GA 30024

# FAN COLUMN

## PRODUCT OVERVIEW

### General Safety Information

This manual provides information on installation, start-up and maintenance for a Price Fan Column (PFC) unit. Improper installation can lead to unsatisfactory operation or dangerous situations. This unit should only be installed and maintained by qualified personnel. Qualified personnel should have a clear understanding of the contents of this manual prior to installation. Improper installation may lead to electric shock, possible injury from contact with moving parts and/or possible burns from contact with heating components. Additional safety precautions may be required.

Installer shall follow all national and local electrical code requirements such as the National Electrical Code (NEC) and the Canadian Electrical Code (CEC) in Canada. Where applicable, follow National Fire Protection Association (NFPA) requirements. The appliance must be electrically grounded in accordance with local codes or, in the absence of local codes, with the National Electrical Code, ANSI/NFPA 70, and /or the Canadian Electrical Code, CSA C22.1, if an external electrical source is utilized.

#### **WARNING** ▾

The manufacturer's warranty does not cover any damage or defect caused by modifications to the unit including unauthorized attachments of other components. Such activity may lead to unsatisfactory performance and may endanger life and property.

**NOTE:** This document is customer property and must be retained by the unit's owner for use by maintenance personnel.

### Safety Notices

Throughout this manual Caution and Warning notices are used where additional safety information may be required. Warnings are provided to alert personnel of a potential situation that could result in personal injury or death. Cautions are provided to alert personnel of a potential situation that could result in personal injury.

In addition to Warnings and Cautions, Notices are used to indicate a situation that may result in property damage.

#### **WARNING** ▾

Indicates a potential situation that, if not avoided, could lead to serious personal injury or death.

#### **CAUTION** ▾

Indicates a potential situation that, if not avoided, could lead to minor or moderate personal injury. Cautions may also be used to indicate unsafe practices.

**NOTICE:** Indicates a situation or action that may cause damage to the unit or the facility.

# FAN COLUMN

## PRODUCT OVERVIEW

### Unit Description

The PFC model is a fan column unit with a vertically mounted plenum fan for use in underfloor systems. The unit is an indoor unit and may include supplemental cooling and/or heating.

### Unit Nameplate

**Figure 1** shows a typical nameplate for a PFC unit. The nameplate is generally located in the control box or near the VFD. The nameplate includes model number, serial number, electrical characteristics and other pertinent data.

### Unit Inspection

This unit has been inspected and tested prior to shipment to make sure the unit is free from defects from the manufacturer. It is possible that damage may occur during shipping, rigging and installation.

Upon receiving the unit, check that all items have been delivered by comparing the Bill of Lading to the equipment received. If anything is missing or damaged, notify the carrier immediately. The carrier should note this on the packing slip or other form of documentation and provide a copy. Note: it is a good idea to take a photograph of any possible damage for record purposes.

Check the unit model number and electrical characteristics to make sure they are correct. If there are any issues, do not proceed with the installation. Contact your sales representative.

### Storage

The unit must be stored indoors in a clean, dry environment on a level surface to prevent damage to the cabinet and components. For long-term storage, rotate the fan wheel every month to maintain proper bearing lubrication.

FIGURE 1: TYPICAL NAMEPLATE ▼

<b>Price Industries Inc.</b> 20 Crestridge Drive Suwannee, GA 30024 Ph: (770) 623-8050 x2144 Price Industries Ltd.					
CONFORMS TO UL STANDARD 1995 CERTIFIED TO CAN/CSA STD C22.2 NO. 236 FOR INDOOR INSTALLATION ONLY		CONFORME À UL STANDARD 1995 CERTIFIÉ À CAN/CSA STD C22.2 NO. 236 POUR L'INSTALLATION À L'INTÉRIEUR SEULEME			
Type of Unit Type d'unité		Commerical Air Handler Unit		Unit Tag Unité Tag	
Model Number Numéro de modèle		PFC-50		Serial Number Numéro de série	
Wiring Drawing No. No diagramme de cablage		MA00099999		Maximum Inlet Water Temperature La température d'eau d'entrée maximale	
Line Voltage Voltage		460		Phase Phase	
Motor FLA FLA du moteur		#N/A		Unit MCA MCA de l'unité	
Control Voltage Voltage de contrôle		N/A		Cycle Cycle	
Supply Air Volume Volume d'air d'alimentation		5,000 CFM		External Static Pressure Pression statique externe	
Fan RPM Tr/min du ventilateur		1,134		Motor Horsepower Puissance du moteur	
				60	
				#N/A	
				N/A	
				0.10" w.g.	
				0.0 HP	

# FAN COLUMN

## INSTALLATION & START-UP INSTRUCTIONS

### Mechanical Installation

#### Location

PFC units are approved for indoor installations only. The installation must conform with local building codes. Typically, PFC units are installed in mechanical closets near the core of the building with one or more per floor.

#### Unit Clearances

Before placing the unit, clearances to walls and other obstructions should be considered.

Maintain minimum clearances as shown in **Figure 2**.

For ease of service, it is also advisable to maintain a minimum of 48" (1.2 m) clearance to the control side of the unit and 24" (60 cm) or more on all other sides.

#### Base

Price PFC units can be installed on a concrete slab. The entire perimeter base and frame structure must be continuously supported by the slab. Shim the base so that it is level and anchor to the concrete slab using the provided brackets. Grout underneath the base in order to continuously support the unit. PFC units typically have a coil and drain pan in the top section of the unit. If mounted on a surface that is not level, proper drainage may not occur.

#### NOTICE: CONTINUOUS STRUCTURAL SUPPORT REQUIREMENT

The unit is designed to have continuous structural support around its entire perimeter. Failure to provide continuous structural support will damage the unit and void the warranty.

**FIGURE 2: MINIMUM CLEARANCES FOR PFC UNITS** ▼

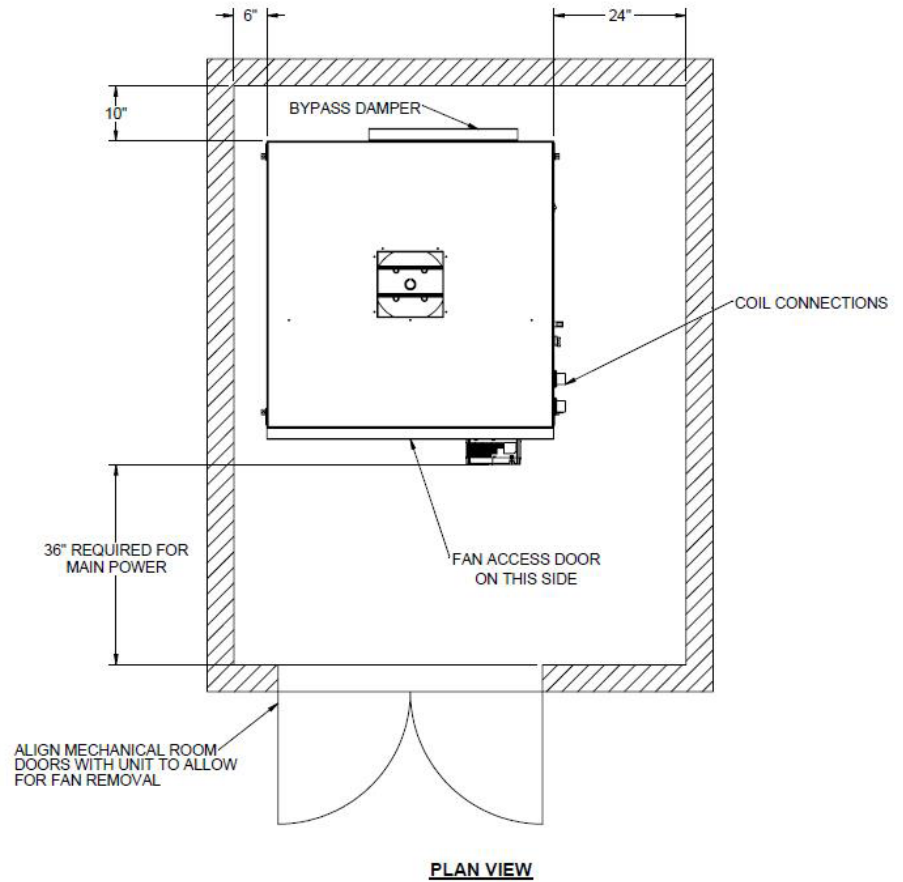

**ANCHOR BRACKETS** ▼

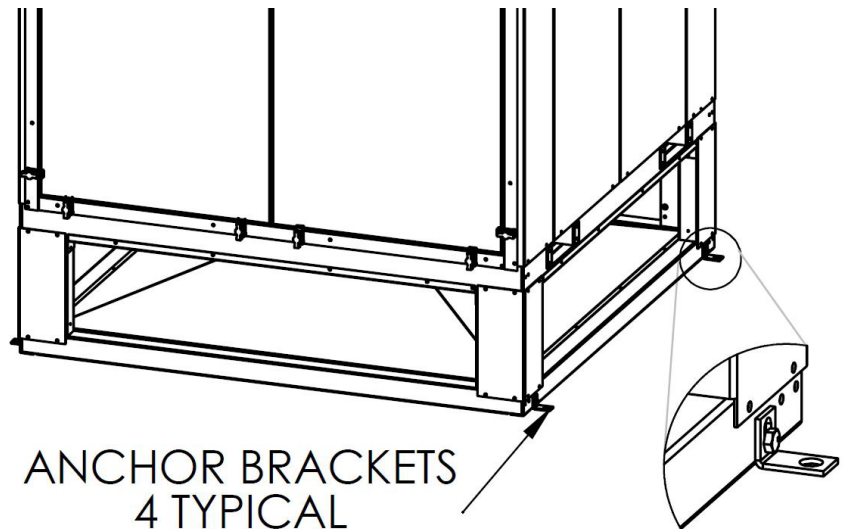

# FAN COLUMN

## INSTALLATION & START-UP INSTRUCTIONS

### Unit Handling



## WARNING ▼

### HEAVY COMPONENTS

Unit sections should be lifted only as shown and lifted as individual ship sections. Do not stack the sections until they have reached the final installation location. The forklift being used must be capable of supporting the weight of the entire section. Forks must extend through the entire unit. Use fork extenders if necessary. Other lifting arrangements may damage the unit. Failure to properly lift each section may result in death or serious injury.

Each section of the PFC unit is provided with openings for the use of a forklift. Sections should be lifted only as shown and described below.

The general lifting method should be followed in all cases:

1. Before lifting, check the unit weight to ensure that forklift is adequately sized. Locate the forklift openings for each section.
2. Fork extenders must be used to make sure the forks extend through the unit for safe lifting.
3. Some units will ship in multiple sections, as shown in **Figure 3**. Only lift the sections as individual ship sections. DO NOT assemble units and attempt to lift entire unit with forklift.

### Unit Installation & Assembly

PFC units may be shipped as a single unit or in sections for field assembly by the installing contractor. Refer to the submittal drawings for section details.

Units that are received in a **single piece** should be assembled as follows:

1. Remove skid, crates, and packing materials.
2. Unit should be placed in the desired location. Ensure that door orientation is correct.
  - a. Some units will have less than 4 discharge openings. In this case, ensure that the unit discharge orientation is correct. If incorrect, remove the cover plates and relocate in the proper location.
3. Shim the base so that it is level and anchor to the concrete slab.
4. Grout underneath the base in order to continuously support the unit.
5. Remove all shipping brackets from the fan section and the shipping cover for the VFD. See **Figure 4**.
6. Install provided covers for forklift openings. See **Figure 7**.
7. Install provided filters according to unit drawings.

### PROPER LIFTING METHOD ▼

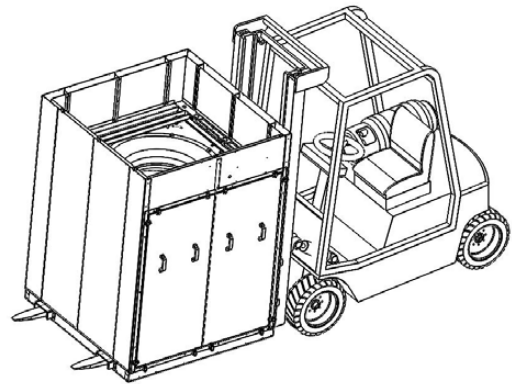

### FIGURE 3: POSSIBLE SHIPPING SCENARIOS ▼

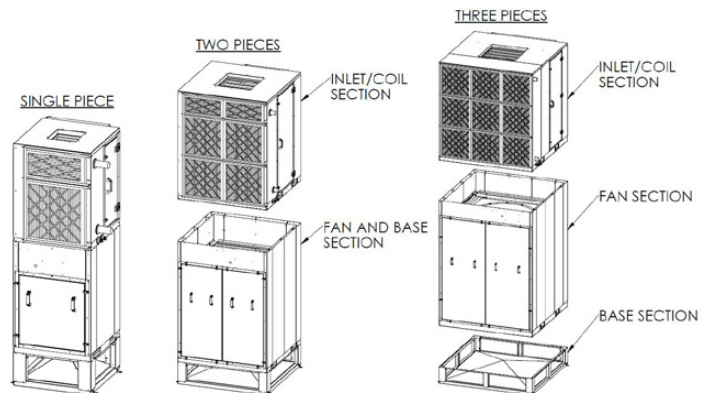

### FIGURE 4: ITEMS TO REMOVE BEFORE OPERATION ▼

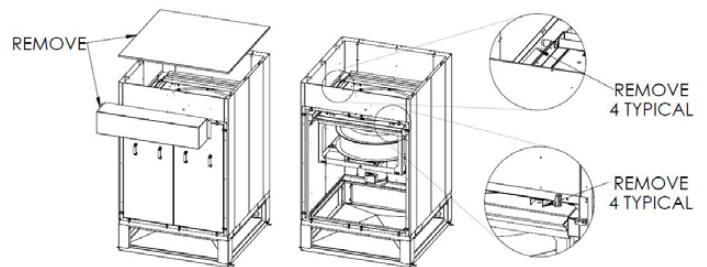

Units that are received in **two pieces** should be assembled as follows:

1. Remove skid, crates, and packing materials.
2. The fan and base section should be placed in the desired location. Ensure that door orientation is correct.
  - a. Some units will have less than 4 discharge openings. In this case, ensure that the unit discharge orientation is correct. If incorrect, remove the cover plates and relocate in the proper location.



# FAN COLUMN

## INSTALLATION & START-UP INSTRUCTIONS

3. Shim the base so that it is level and anchor to the concrete slab.
4. Grout underneath the base in order to continuously support the unit.
5. Remove the section rain cover, all shipping brackets from the fan section, and the shipping cover for the VFD. See **Figure 4**.
6. Stack the inlet/coil section on top of the fan section. See **Figure 3** for details. Ensure coil connections are on the correct side of the unit.
7. Fasten the sections together using provided screws (#10 Type AB). See **Figure 5**.
8. Remove all forklift sleeves from the unit and install provided covers for forklift openings. See **Figure 7**. This must be done before mechanical room walls are installed.
9. Install provided filters according to unit drawings.

Units that are received in **three pieces** should be assembled as follows:

1. Remove skid, crates, and packing materials.
2. The base section should be placed in the desired location.
  - a. Some units will have less than 4 discharge openings. In this case, ensure that the unit discharge orientation is correct. If incorrect, remove the cover plates and relocate in the proper location.
3. Shim the base so that it is level and anchor to the concrete slab.
4. Grout underneath the base in order to continuously support the unit.
5. Stack the fan section on top of the base section. See **Figure 3** for details. Ensure that door orientation is correct.
6. Fasten the sections together using provided screws (#10 Type AB). See **Figure 6**.
7. Remove the section rain cover, all shipping brackets from the fan section and the shipping cover for the VFD. See **Figure 4**.
8. Stack the inlet/coil section on top of the fan section. See **Figure 3** for details. Ensure the coil connections are on the correct side of the unit.
9. Fasten the sections together using provided screws (#10 Type AB). See **Figure 5**.
10. Remove all forklift sleeves from the unit and install provided covers for forklift openings. See **Figure 7**. This must be done before mechanical room walls are installed.
11. Install provided filters according to unit drawings.

**NOTE:** Seal the raised floor tightly to the unit to make sure there is no air leakage.

**FIGURE 5: INLET TO FAN SECTION FASTENING** ▼

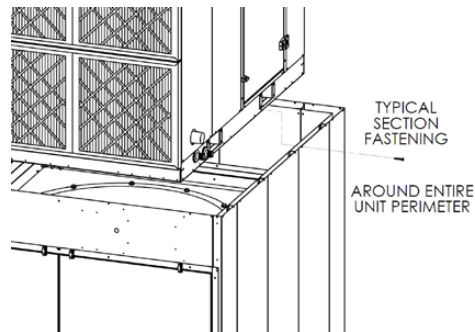

**FIGURE 6: FAN TO BASE SECTION FASTENING** ▼

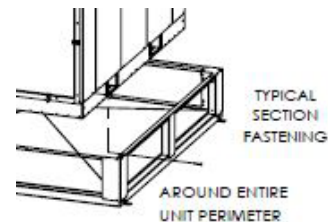

**FIGURE 7: FORKLIFT SLEEVES AND COVERS** ▼

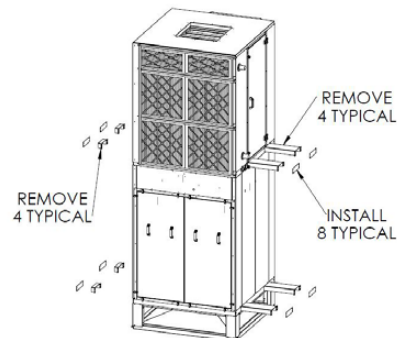

### Duct Connections

**NOTE:** Not all units require ductwork. This section can be ignored if no ductwork is required.

For all duct connections, the ductwork will be connected to the unit casing using sheet metal screws by the installing contractor. Unless indicated on the submittal drawings, the weight of the ducting should not be placed directly on the unit. The installing contractor should provide an external means to carry the duct weight.

Access panels in the ducting near the unit are recommended. Where no access to the unit inlet or discharge section is provided as part of the unit (for example an access door in the unit), access panels are strongly recommended for inspection and service.

Before starting installation, examine all components for possible shipping damage.

# FAN COLUMN

## INSTALLATION & START-UP INSTRUCTIONS

### Electrical Installation



#### WARNING ▼

##### ELECTRICAL SHOCK HAZARD

Disconnect all electric power, including remote disconnects before servicing. Follow proper lockout/tagout procedures to ensure the power cannot be inadvertently energized. Failure to disconnect power before servicing could result in death or serious injury.

##### NOTICE: USE COPPER CONDUCTORS ONLY

Unit terminals are designed for copper conductors only. Failure to use copper conductors may result in unit damage.

### Main Power Connection

All connections to the unit and the main disconnect switch must conform to the Canadian Electrical Code/National Electrical Code and local codes.

1. Before proceeding with electrical connections, ensure that the unit characteristics and the intended supply match. The proper voltage for connection is listed on the rating plate attached to the unit.
2. Unit must be electrically grounded in accordance with local codes, or in the absence of local codes, with the National Electrical Code, ANSI/NFPA 70, and /or the Canadian Electrical Code, CSA C22.1, if an external electrical source is utilized.
3. Where a disconnect is supplied as part of the unit, the main power connection will be the line side of the disconnect.
4. If the unit is not supplied with a factory mounted disconnect, a field supplied disconnect must be installed in accordance with local codes, or in the absence of local codes, with the National Electrical Code, ANSI/NFPA 70, and /or the Canadian Electrical Code, CSA C22.1.
5. Ensure that the routing of the power supply wiring does not interfere with removal of any unit access door, or in any way hinder servicing of the unit.
6. For units that are shipped in multiple sections, some electrical connections may have to be made by the installer in the field. Field wiring to be done by the installer appears as a dotted line on the wiring diagram.
7. Installing contractor to supply appropriate fusing and branch circuit protection.

### TYPICAL FACTORY SUPPLIED DISCONNECT ▼



8. If any of the original wires need to be replaced, they must be replaced with type TEW 105° or equivalent except where noted.
9. Make sure that motor rotation is correct as connected.

### Auxiliary Power Connections

A separate 120/1/60 power supply may be required on units with convenience outlets and lights. Refer to unit wiring diagrams for wiring sizing details and connection points. Overcurrent protection for this circuit must be provided by others.

### Controls Installation

All field wiring must be in accordance with local codes, or in the absence of local codes, with the National Electrical Code, ANSI/NFPA 70, and /or the Canadian Electrical Code, CSA C22.1.

Field controls wiring requirements will depend on the controls provided with the unit. A basic unit will require controls by others. A controller or thermostat must be provided by the installing contractor. Refer to unit electrical wiring diagrams for details.

Units supplied with controls may require field wiring to a remote sensor or control panel. Refer to unit electrical wiring diagrams for details.



# FAN COLUMN

## INSTALLATION & START-UP INSTRUCTIONS

### Hot Water and Chilled Water Coil Connections

**NOTICE: IMPROPER PIPING MAY LEAD TO UNIT AND BUILDING DAMAGE**

Improper piping on hot water and chilled water coils may lead to leaks that can damage the unit and the building. Follow these instructions carefully.

Some units may include hot water and/or chilled water coils. All units will have the piping connections stubbed out through the panels. Refer to the submittal drawings for piping arrangements.

1. All piping connections should be counterflow, with respect to air flow. Confirm that the coil can be piped properly. If not, do not continue piping. Contact your sales representative.
2. Hot water and chilled water coils are generally not supplied with any piping or control valves. The installing contractor is responsible for all field piping and leakage tests.
3. Route properly-sized piping to the coils. Include control and isolation valves as required.
4. Use a backup wrench whenever attaching fittings to the coils. Failure to do so will damage the coils and void the warranty.
5. Leak test the unit prior to filling the system. Repair all leaks and re-test prior to filling the system.
6. Bypass coils during system flush. Failure to do so may cause debris to be caught in control valves and/or the coil.

### Cooling Device Condensate Traps

**NOTICE: IMPROPER TRAPPING MAY FLOOD UNIT**

Improper condensate traps may flood the unit leading to damage of both the unit and the building. Follow the instructions below carefully.

The PFC unit may have a chilled water cooling coil or other condensate producing device that includes a condensate pan. Devices that include a condensate pan will require a field supplied condensate trap. The height and configuration of the trap will depend on the location with respect to the supply fan and the supply fan total static pressure. Particularly in the case of a draw through trap, improper trapping may stop the condensate from draining and cause the unit to flood. This can damage both the unit and building.

There is also a drain pan overflow pipe in case of blockage of the main condensate drain. The connection to this overflow

### OPTIONAL LIGHTING PACKAGE ▼

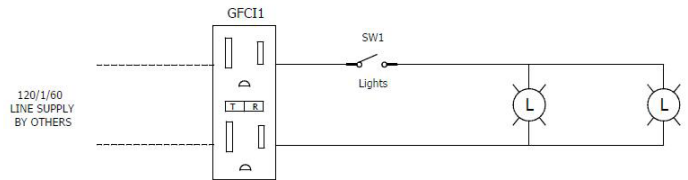

### COOLING COIL CONDENSATE ▼

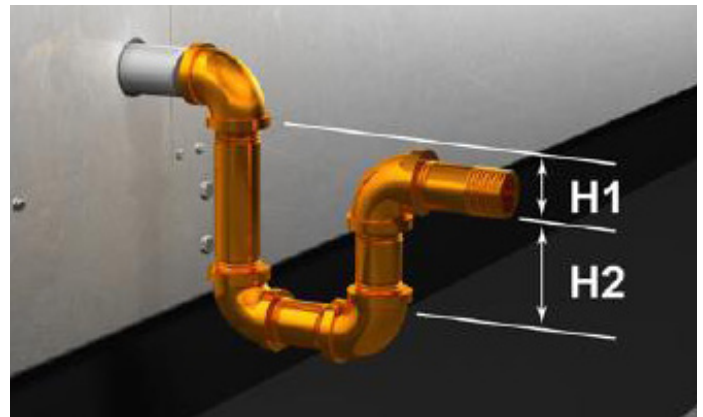

drain will require field piping and must meet local code requirements for overflow drains. A condensate trap must also be provided for this connection and must be properly sized.

#### Trap Sizing

$H1 = \text{supply fan TSP} + 1 \text{ inch}$

$H2 = 0.5 \times H1$

*Example*

Size a condensate trap for a unit with TSP of 1.5 in w.c.

$H1 = 1.5 + 1 = 2.5 \text{ inches}$

$H2 = 0.5 \times 2.5 = 1.25 \text{ inches}$

# FAN COLUMN

## INSTALLATION & START-UP INSTRUCTIONS

### Installation Checklist

The following checklist is a summary of all the steps necessary for a successful start-up. This is not intended to replace the detailed information in the applicable sections of this manual.

Task	Complete
<b>General</b>	
Inspect unit for freight damage or missing items on the bill of lading.	
Confirm the installation location meets the necessary clearances.	
Set unit on level slab.	
Check that unit and discharge orientation are correct.	
Check that unit is level and shim if required.	
Anchor the base to concrete slab.	
Grout underneath to continuously support the base.	
Remove shipping hold downs, shipping braces etc. From unit.	
Stack unit sections and fasten together.	
Remove forklift sleeves and install covers for forklift openings.	
Install any components shipped loose for field installation.	
Check all fan isolators for proper adjustment and operation.	
Install filters as required.	
<b>Electrical connections</b>	
Confirm that main electrical supply matches the name plate requirements.	
Inspect control cabinets and tighten any loose connections.	
Provide disconnect if one is not factory supplied.	
Connect power supply to factory or field supplied disconnect.	
Properly ground the unit.	
<b>Control wiring connections</b>	
Complete controls wiring as per the wiring diagrams.	
<b>Hot water and chilled water coil connections</b>	
Confirm coils can be piped correctly.	
Route properly sized piping to the coil connections.	
Leak test piping.	
Install cooling device condensate drains if required.	

# FAN COLUMN

## INSTALLATION & START-UP INSTRUCTIONS

### **WARNING** ▾

#### **ELECTRICAL SHOCK HAZARD**

Disconnect all electric power, including remote disconnects before servicing. Follow proper lockout/tagout procedures to ensure the power cannot be inadvertently energized. Failure to disconnect power before servicing could result in death or serious injury.

### **WARNING** ▾

#### **HAZARDOUS SERVICE PROCEDURES**

During installation, testing, servicing and troubleshooting of this product it may be necessary to work with live electrical components and moving mechanical components. Have a qualified technician who has been properly trained in handling live electrical components perform these tasks. Failure to follow all electrical safety precautions when exposed to live electrical and mechanical components could result in death or serious injury.

### **Before Start-Up**

Prior to starting the unit and with the main disconnect in the “OFF” position, make sure the following work is complete:

### **Electrical Power Check**

### **WARNING** ▾

#### **HAZARDOUS SERVICE PROCEDURES**

During installation, testing, servicing and troubleshooting of this product, it may be necessary to work with live electrical components and moving mechanical components. Have a qualified technician who has been properly trained in handling live electrical components perform these tasks. Failure to follow all electrical safety precautions when exposed to live electrical and mechanical components could result in death or serious injury.

Prior to powering the unit, it is crucial to check the incoming electrical power as follows:

1. Check that the electrical power matches the name plate data.
2. Check that the voltage on each leg is within the stated voltage range and/or does not exceed 110% of name plate value.
3. Check that the voltage difference on all three phases is within 2%.

If any of these conditions are not met, do not continue commissioning the unit. Arrange to have the power issue resolved.

Task	Complete
<b>General</b>	
All steps in installation check list are complete.	
<b>Fan Inspection</b>	
Shipping hold downs and braces have been removed from the unit. Manually rotate fan and confirm it moves freely.	
All fan set-screws have been checked for tightness.	
<b>Electrical</b>	
Electrical power is acceptable (see below).	

# FAN COLUMN

## INSTALLATION & START-UP INSTRUCTIONS

### Fan Start-Up



#### HAZARDOUS ROTATING EQUIPMENT

Contact with the rotating fan or motor can lead to death or severe injury. Follow proper lockout/tagout procedures to ensure the power cannot be inadvertently energized.

Once the unit has been started, an air balance should be performed by a qualified technician.

1. Confirm that the air flow matches the design air flow indicated on the submittal documents.
2. If VFD speed changes are made to achieve the design air flow, confirm that the supply fan motor amp draw is acceptable and the fan speed does not exceed the fan rating.

Once the power has been checked, the fan rotation needs to be checked as follows:

1. Turn the disconnect on.
2. Turn the VFD on and allow the fan to start spinning for a few seconds. Then turn off the VFD and check the rotation. There is typically an arrow on the fan housing to indicate rotation direction.
3. If the fan rotation is not correct, shut down the unit and turn off the power. Switch any two of the power leads at the load side of the disconnect.
4. Check the fan motor amp draw and compare it to the nameplate rating. If the amp draw is too high, correct the air flow and/or duct static pressure drop to reduce amp draw. If the fan speed is adjusted, make sure not to exceed the maximum fan speed rating.

### Air Balance

#### NOTICE: IMPROPER AIR BALANCE

Operating the unit outside of its design air flow range can lead to premature fan and motor failure. Follow the requirements listed below. Failure to provide correct air flow through the unit will void the warranty.

# FAN COLUMN

## Typical Sequence of Operation

Price PFC units may be customized with a wide variety of controls options. Refer to the submittal documents for the specific control sequence of operation.

## Maintenance



### HAZARDOUS SERVICE PROCEDURES

During installation, testing, servicing and troubleshooting of this product, it may be necessary to work with live electrical components and moving mechanical components. Have a qualified technician who has been properly trained in handling live electrical components perform these tasks. Failure to follow all electrical safety precautions when exposed to live electrical and mechanical components could result in death or serious injury.

Regular maintenance is the best way to avoid untimely and expensive repairs, and it extends the useful life of the equipment. Maintenance should only be performed by qualified service personnel familiar with this equipment and local codes and requirements.

Maintenance Item	Quarterly	Annually
<b>General Maintenance</b>		
Inspect inside of unit for water leaks, foreign material etc.	✓	
Clean or replace filters with equivalent to those supplied by manufacturer.	✓	
Check cooling device drain pans and traps for cleanliness and blockage.	✓	
Check all dampers, linkages and damper actuators and adjust and tighten as required.	✓	
Check cooling or heating coils for cleanliness and clean as necessary.		✓
<b>Fan Maintenance</b>		
Inspect fan wheel and housing, clean as necessary.		✓
<b>Electrical Maintenance</b>		
Check for loose wire connections in control panel.	✓	
Check motor amp draw against name plate.	✓	
Inspect all contactors to ensure they are clean and making good contact.	✓	

# FAN COLUMN

## MAINTENANCE

### Price PFC Start-up Report

#### General

Job Name: \_\_\_\_\_ Order Number: \_\_\_\_\_  
Serial Number: \_\_\_\_\_ Unit Model Number: \_\_\_\_\_  
Installation Street Address: \_\_\_\_\_ City: \_\_\_\_\_  
Province/State: \_\_\_\_\_ Postal Code/Zip: \_\_\_\_\_  
Service Company Name: \_\_\_\_\_ Company Phone Number: \_\_\_\_\_  
Name of Service Technician Performing Start-up: \_\_\_\_\_

#### Start-Up Checklist

CAUTION: High Voltage may be present. Disconnect all power supplies prior to performing start-up check list.

- Exterior – look for damage to housing, doors, handles, fittings, etc.  
If damaged indicate where: \_\_\_\_\_
- Interior – look for damage to fans and components.  
If damaged indicate where: \_\_\_\_\_
- Remove all foreign material from unit
- Check that all dampers are secure
- Check that all openings and penetrations are sealed
- Check fan rotation
- Rotate each fan wheel by hand to ensure it spins freely
- Tighten all fasteners
- Tighten all set screws and lock collars for motors, dampers and accessories
- Verify that non-motorized dampers (if installed) open and close properly
- Verify proper drain trap installation (two required)
- Check for any loose electrical connections
- Check and tighten all unit terminals strips (if supplied)
- Check that the disconnect mechanism / mechanical interlocks work properly (if supplied)
- Check that the disconnect and fusing are properly sized
- Ensure all system components are adjusted to proper settings (temperature controllers, overloads, etc.)



# FAN COLUMN

## Set Points

Discharge Temperature Set Point (°F)	
Space Temperature Set Point (°F)	

## Fan

Fan Information	Supply Fan					
Air flow (CFM)						
Underfloor Static Pressure (in W.C.)						
Return Static Pressure (in W.C.)						
Fan Type						
Motor Make / Hp						
Motor Voltage / Phase						
Motor Rated Amps						
Blower RPM	<b>Tested</b>					
Tested Motor Voltage	<b>1-2</b>		<b>2-3</b>		<b>3-1</b>	
Tested Motor Amp Draw	<b>L1</b>		<b>L2</b>		<b>L3</b>	
Shipping Brackets Removed						

## Comments

---



---



---



---



---



---



---



---

Signature: \_\_\_\_\_

Date: \_\_\_\_\_

# FAN COLUMN

---

## MAINTENANCE

### Price PFC Quality Assurance Report

[underfloor@priceindustries.com](mailto:underfloor@priceindustries.com)

#### Initial Inspection

Any visible damage?  Yes  No  N/A

Please describe the damage: \_\_\_\_\_  
\_\_\_\_\_

#### Unit Start-up

How is the overall fit and finish?  Needs Improvement  Satisfactory  Excellent

Were there any electrical or controls issues?  Yes  No  N/A

Please describe the issue: \_\_\_\_\_  
\_\_\_\_\_

Were the schematics, manuals, labels etc. useful?  Yes  No  N/A

How could we make them better?: \_\_\_\_\_  
\_\_\_\_\_

#### Additional Comments and Suggestion on How to Improve Our Products and Services

---

---

---

---

---

#### Service and Warranty Procedure

##### Replacement Parts

Replacement parts can be obtained from Price Industries at [underfloor@priceindustries.com](mailto:underfloor@priceindustries.com) or 770-623-8050. When contacting Price for replacement parts, refer to the model number and serial number on the name plate.





---

This document contains the most current product information as of this printing.  
For the most up-to-date product information, please go to [priceindustries.com](http://priceindustries.com)

© 2021 Price Industries Inc. All rights reserved.

**price®**